



**Shipping & Mailing**  
Postage management

# mailstation™ / mailstation 2™ Digital Postage Meter

**Install Guide**  
US English Version



# Contents

Communication Device



Network Cable

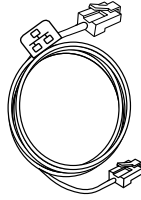

USB Cable

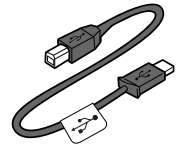

Scale



mailstation  
Ink Cartridge  
Reorder #797-0

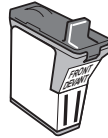

OR

mailstation 2  
Ink Cartridge  
Reorder #797-M

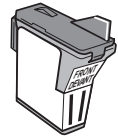

Meter

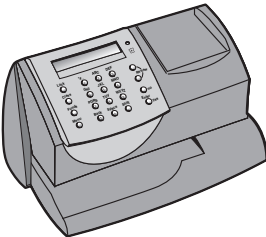

Power Cord



Sample Pack of  
Tape Sheets  
Reorder #612-9



Install Guide



Scale Extension  
Cable #978-6  
(Optional)

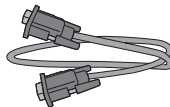

# Read This First

To take advantage of the web-based capabilities of your meter, it must be connected to your network.

If network access is available for your meter, you can:

- Watch a step-by-step installation video by scanning the QR Code below with your smartphone

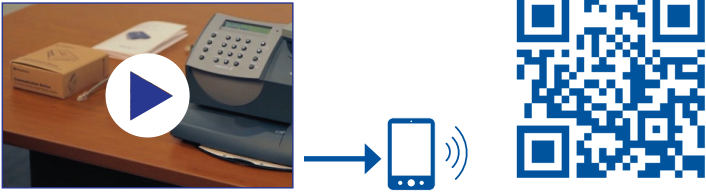

or

- Enter the following URL at your computer:  
**[www.pb.com/support/new/K7](http://www.pb.com/support/new/K7)**

or

- Follow this printed installation guide, starting on page 1



# Installation Part 1

## Set Up Communication Device

### Step 1. Preparing for Installation

To install your meter using the Internet, you will need the following:

- **Two power outlets**
- **An Internet source**, such as a router, hub or network wall jack.

**Note 1:** DO NOT use a port in a computer to connect to your network.

**Note 2:** DSL VoIP phone jacks cannot be used as an Internet source.  
Do not connect a DSL phone jack directly to the meter.

Access to a computer during installation is recommended.



**Wireless:** Step 2 through Step 8 must be completed before wireless installation.

#### Technical Requirements:

##### IP Address

- Automatic assignment with DHCP and DNS server capability (most networks have this), or
- Manually specified static IP (not shared with other devices on your network).



If your network requires special settings, such as static IPs or proxy settings, your IT specialist should use the Special Network Settings instructions in this booklet, as part of the installation.

##### Proxy Server (if needed)

If your network uses Static IPs or Proxies, the setup software requires:

##### Operating System:

- Windows 2000, Windows XP, Windows Vista, Windows 7
- Mac OS X (PowerPC: Ver10.3.x ~ Ver10.5.5)

## Step 2. Locate the Communication Device and Network Cable

The Communication Device enables your meter to connect to Pitney Bowes via the Internet to access postage downloads. It's packaged in its own cardboard box.

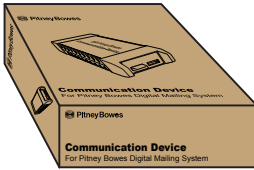

Communication Device

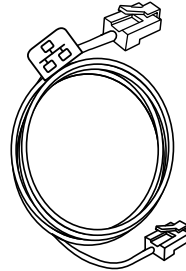

Network Cable

## Step 3. Connect the Communication Device to your Internet source

Be sure to connect to an active network port.

**Note:** If you are not certain where to connect, or whether your network requires special settings, consult your IT specialist.

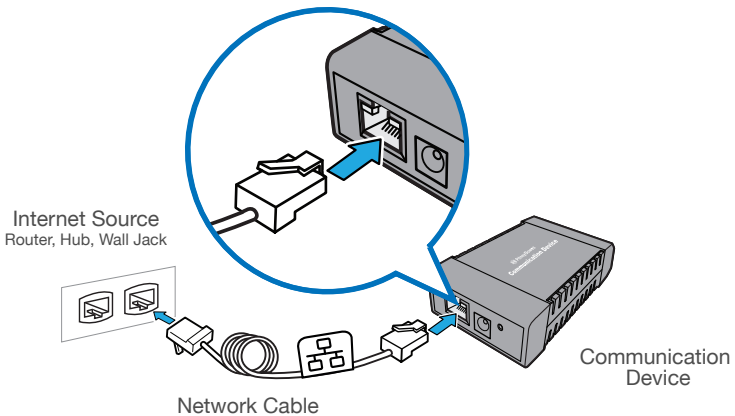

**DO NOT** use a port in a computer to connect to your network.

## Step 4. Apply power to the Communication Device

Plug the AC adapter (🔌) into the Communication Device and a power outlet. The left LED is lit **yellow** when it is on.

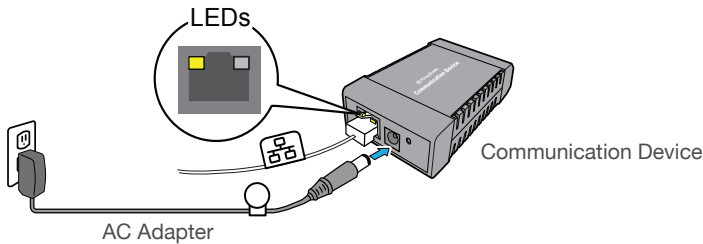

## Step 5. Check LED

After 45 seconds, the right LED will blink **orange**, go to Step 6.

If the right LED is solid **orange** (not blinking), follow Troubleshooting 1, below.

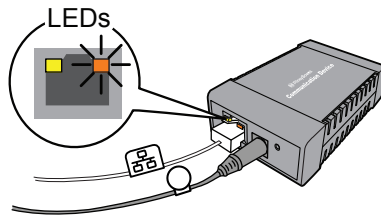

### Troubleshooting 1

Communication Device may not be communicating to an active network port.

Try the following:

- Be sure the Network Cable (🔌) is properly connected at both ends.
- Try other ports (for 10 seconds each) until you find one that is active (LED changes from solid orange to **green**). Do not use a network port in a computer.
- Pull the power connector (🔌) out, then reconnect power to restart the Communication Device.
- If after 45 seconds, the right LED is still not blinking **orange** only, consult your IT specialist. Your IT specialist may need to follow the Special Network Settings procedure on page 6.
- For more detailed technical assistance, go to: [www.pb.com/support/LAN](http://www.pb.com/support/LAN)

## Step 6. Connect the meter to the Communication Device with the USB Cable

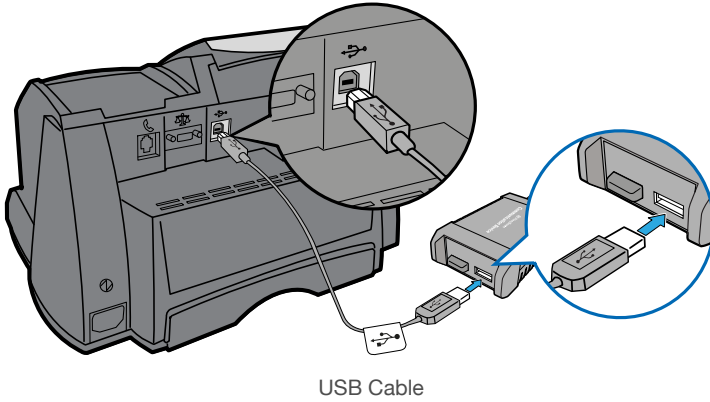

## Step 7. Connect the meter to a power outlet

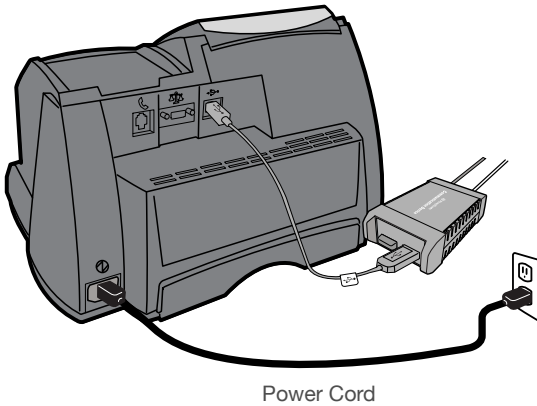

When power is applied, the meter will display its startup screens and you will hear the meter's printer initialize.



## Step 8. Confirm Connection

About 10 seconds after the meter completes its startup routine, it displays the message:

```
Meter connected to
internet-Press Enter
```

Also, the right LED changes from blinking orange to blinking **green** only.

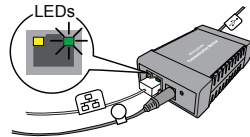

If the right LED lights orange, either solid or blinking, see Troubleshooting 2 below.



DO NOT press Enter on the meter yet.

For wireless connection and meter setup go to Step 9 on page 7.

### Troubleshooting 2

If the meter does not display the message, “Meter connected to Internet”, your meter is not communicating with the Internet.

Try the following:

- Check that the USB Cable (  ) is connected properly.
- If the right LED is solid **orange** (not blinking), then the network cable is connected to an inactive port. Try other ports (for 10 seconds each) until you find one that is active (LED changes from solid orange to **green**).
- Restart the Communication Device by pulling the power connector (  ) out, then reconnecting the power.
- If, after 60 seconds the message, “Meter connected to internet” is not displayed, consult your IT specialist.

Your IT specialist can refer to online troubleshooting assistance at:  
[www.pb.com/support/LAN](http://www.pb.com/support/LAN)

## Special Network Settings

This section is needed only if your network requires special settings to operate properly, such as static IPs and proxy server IDs, the settings will need to be added to the Communication Device. Consult your IT specialist to determine if this is necessary. Follow instructions exactly in the sequence shown below.

### To enter special settings

- a. Disconnect power (⏻) from the meter.
- b. Be sure the Communication Device is:
  - connected to an active Internet port
  - plugged into a power outlet
  - the right LEDs are blinking in an orange and/or green pattern.
- c. Download the setup software to your computer by going to:  
**[www.pb.com/support/netsetup](http://www.pb.com/support/netsetup)**  
Click the button for your type of computer.

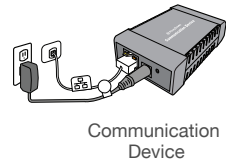

**Note:** If a firewall message appears, click the button that allows the download to proceed.

- d. Save the software “pbSmartLAN” to your computer, then open and run it.
- e. Click the **Setup for Network Cable Connection** button.



Follow the setup wizard and enter the appropriate special settings.

# Installation Part 2

## Set Up Meter

### Step 9. Wireless Connection (Optional)

To set up wireless capability, go to: **[www.pb.com/support/LAN](http://www.pb.com/support/LAN)**  
Scroll down to select the link Wireless Setup Instructions.

Once your meter is connected to the internet wirelessly, begin meter installation on Step 10 below.

### Step 10. Install Scale

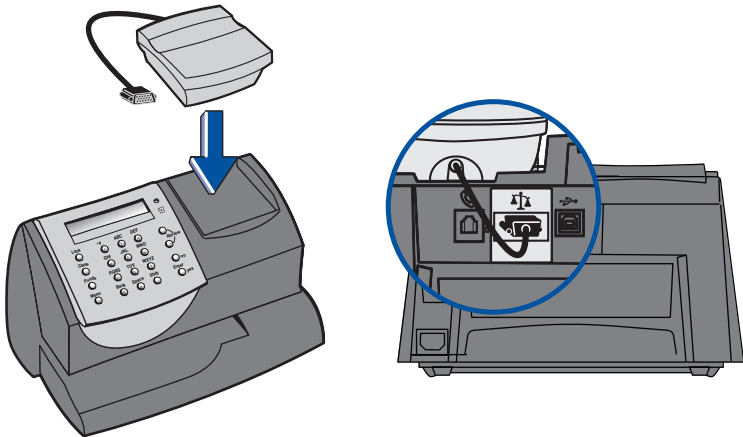

Position the scale on top of the meter as shown.

Connect the scale cable to the scale connector on the back of the meter at the scale icon.

Tighten the screws to ensure a secure connection.

## Step 11. Install Ink Cartridge

Add ink cartridge.  
Continue-Press Enter

- A** 1. Press the **Enter** key on the control panel.

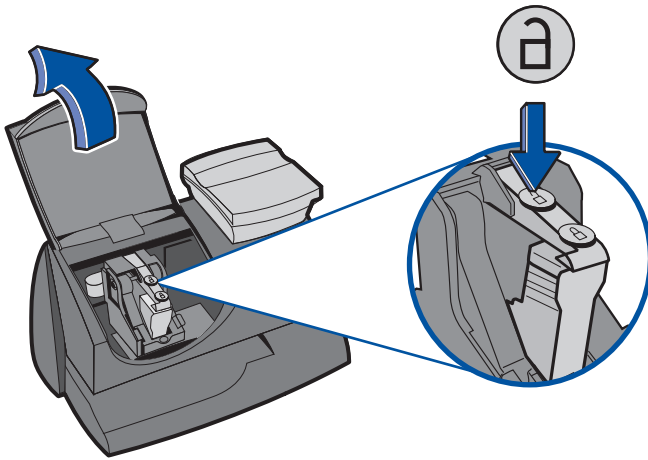

2. Lift the cover.

**NOTE:** If the carriage is not visible close the cover and press **Enter**.

3. Press unlock symbol  to open cartridge cover.

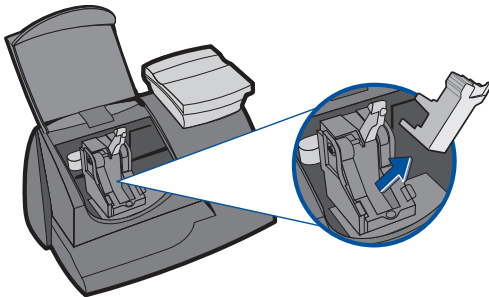

4. Remove and discard the yellow insert.

## Step 11. Install Ink Cartridge (continued)



**B** Remove new cartridge from plastic bag.



**C** Remove silver foil strip from bottom of ink cartridge.

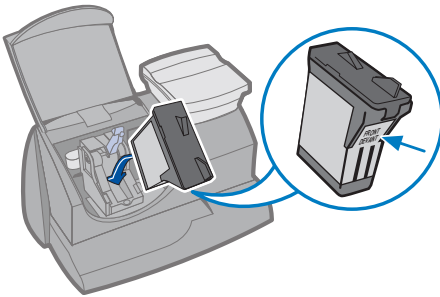

**D** Install new cartridge into machine.

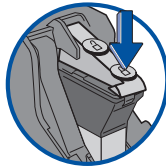

**E** Press ink cartridge cover near the front edge to lock the cartridge in place.

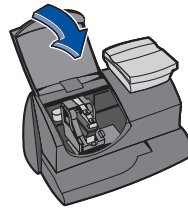

**F** Close Cover. Press .

IMPORTANT - Is Ink  
Cartridge installed?

**G** Press **Enter**. Please wait about 2 minutes.

## Step 12. Create a Test Print

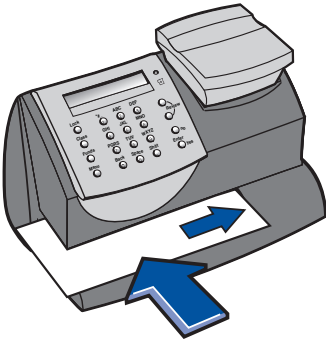

**Attention:** To print correctly, insert tape or envelope against the rear and side walls. The system will detect the envelope and automatically begin printing.

When prompted, insert a spare envelope or a tape sheet for a test print.

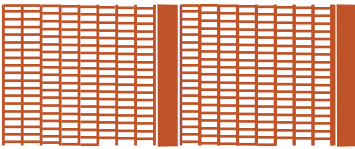

### NOTE:

The test print will appear in red ink.

Good test print - no missing inside lines

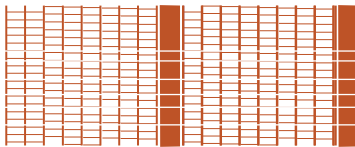

Poor test print - missing inside lines

If the test print is poor, press **no** to perform additional printer maintenance and print another test image.

If the test print is good, press **yes**.

## Step 13. Checking Your Account Balance and Adding Postage to Your System

Your postage meter does not come with pre-loaded postage. Any postage that may be included in your order is on your account. You must connect to the Pitney Bowes Data Center to check your account balance and download postage to the meter.

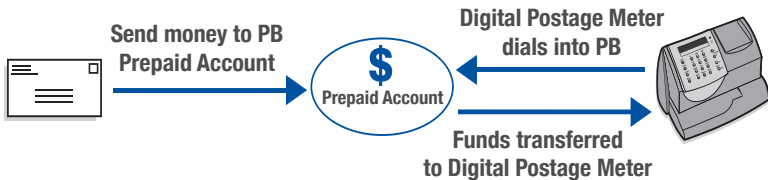

1. When your meter has successfully connected to the Pitney Bowes Data Center, your account balances will display.

Prepaid:	\$0.00	Prepaid Account
Other:	\$20.00	Credit



If you are using a credit card to pay for postage, Prepaid and other balances may display \$0.00 even though funds for postage are available.

2. Press **Enter** to type in amount of postage to add to the meter.
3. If you would like to add postage in an amount other than the initial default, key in the amount of postage you want to add and press **Enter**. You can only enter whole dollar amounts. Confirm this amount by pressing **yes**.
4. After adding postage you will be asked if you want a receipt. Press **yes** if you want a receipt. You will then be prompted to insert an envelope or tape sheet. Press **no** to skip the receipt.

## Step 14. Updating Your Software

After loading postage into your system, the meter will automatically download any relevant updates.

You will see the screen displaying the status of the update.

Complete 53%	2 of 5
remaining	4:21 min

## Step 15. Congratulations! Your meter is operational

\$0.45	01b 0.0oz
1st cl Ltr	MAY 26

Your system is now ready to use.

Also use the Quick Reference Guide under your meter for How To's on:

- Printing Postage
- Locking the meter
- Replacing Ink Cartridge
- Using Ads / Messages
- Changing the Display Contrast
- And More



# Contact List

## If You Need Assistance

- Product Name: mailstation™ or mailstation 2™ or Communication Device
- For Setup or Getting Started questions go to:  
**[www.pb.com/support/LAN](http://www.pb.com/support/LAN)** or call **1-800-522-0020**
- For Product support go to: **<http://support.pb.com/K700>** or **<http://support.pb.com/K7M0>**
- To order Pitney Bowes supplies and accessories, call **1-800-243-7824** or go to:**[www.pb.com](http://www.pb.com)** and click on Online Store.







3001 Summer Street  
Stamford CT 06926  
www.pitneybowes.com

For Service or Supplies

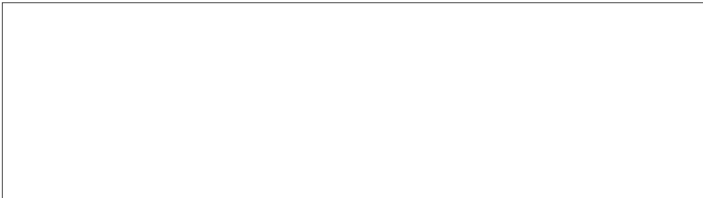

Support Web Site: <http://support.pb.com/K700>  
<http://support.pb.com/K7M0>

Product Customer Support: 1(800) 522-0020

Product Name: mailstation™ / mailstation 2™ / Communication Device

Model Number: K700 / K7M0

AW31214 Rev. H 02/16

© 2016 Pitney Bowes Inc.

All Rights Reserved

Printed in the USA



\* A W 3 1 2 1 4 R E V H \*